



Series 8000

Installation and User Instructions

**All instructions must be handed to user for safekeeping
This is not a DIY product and must be installed by a Gas
Safe registered installer**

**Please ensure both the appliance and trim instructions are read prior
to commencing with installation**

Edition J 05/21

Countries of destination - GB/IE

INSTALLATION INSTRUCTIONS

Please read instructions prior to commencing with installation

This appliance is an Inset Live Fuel Effect appliance that provides radiant or combined radiant and convected heat; it cannot and **should not** be used as the main heating source within a property.

This appliance is designed to fit most types of fireplaces with a natural draught flue as listed in the Installation Requirements.

The appliance must be installed by a competent person in accordance with the Gas Safety (Installation and Use) Regulations 1998. A Gas Safety Registered installer must be used for this purpose.

Read all these instructions before any installation takes place and in conjunction with the appliance on site.

This appliance must be installed in accordance with the rules in force and only used in a sufficiently ventilated space.

This appliance is factory set and tested for operation on the gas type, and at the pressure stated on the appliance data plate.

After a new gas appliance (excluding flueless cookers) has been fitted, the Building Regulations in England and Wales require that the installation must be notified to your Local Authority. Your Gas Safe registered engineer needs to do this, failure to register the appliance may affect your warranty.

Prior to installation, ensure the local distribution conditions (identification of the type of gas and pressure) and adjustment of the appliance are compatible.

OPENING THE APPLIANCE

Ensure the carton is stood the right way up, open the box from the top.

Read all the instructions before continuing to unpack or install this appliance.

Remove the bags containing ceramic components such as coals or gravel etc. Remove the cardboard packing pieces, and any other bags or boxes containing fittings or other parts.

When all loose parts have been removed, the appliance may be unsecured from wooden pallet and lifted out.

Check that the components supplied correlate with the component checklist below.

If any of the listed components are missing or damaged do **NOT** commence with this installation, doing so will invalidate the warranty. Please contact Sirocco Fires for a replacement.

Please dispose of all the packaging materials responsibly at your local recycling centre.

CONTENT CHECK LIST

Qty	Description
1	Firebox and burner tray
1	Decorative trim/frame (may be in separate carton)
1	Fuel bed
1	Set of manufacturer's instructions and warranty card
4	Fixing screws
4	Rawlplugs
1	Remote control handset and battery holder pack (for remote option) main's adaptor (suite and frameless options only)

When fitting the frameless option to be plastered in or for use with marble slips including the integrated steel back panel option, then you must read the additional instructions prior to commencing this installation

INSTRUCTION CONTENT

Section

Contents

Page No

1	Important notes	5
2	Installation requirements	6
3	Appliance Information	7
4	Ventilation	8
5	Site Requirements	8/9
5.1	Prefabricated flue box	10
6	Debris space	11
7	Installation of appliance	11
7.1	Preparing the opening	13
7.2	Fitting the burner tray	17
8	Fuel bed	19
9	Fitting the outer frame/ trim	20
10	Commissioning the appliance	22
10.1	Spark failure	22
11	Setting pressure	23
12	Spillage monitoring system	23
13	Testing for spillage	24
14	Briefing the customer	25
15	Servicing	25
17	User instructions	26
17a	Troubleshooting guide	35
18	Cleaning the coals	39
19	List of spares & contact details	41
20	Warranty details	42

Section 1: IMPORTANT NOTES

This fire is an Inset Live Fuel Effect Gas Fire providing radiant warmth. It is designed to operate on Natural Gas.

Under UK Law all gas appliances and fittings must be installed by a competent person such as a Gas Safe Registered fitter and in accordance with the Gas Safety (Installation and Use) Regulations 1998, the relevant British Standards for Installation, Codes of Practice and in accordance with the manufacturer's Instructions.

The installation must be carried out in accordance with the following regulations:

The Building Regulations issued by the Department of the Environment, the Building Standards (Scotland) (Consolidation) Regulations issued by the Scottish Development Department.

- BS 4543 part2
- BS 5440 parts 1&2
- BS 5871 part 2
- BS 6461 parts 1&2
- BS 6891
- BS 8303

Failure to comply with these regulations may lead to prosecution and invalidate your warranty.

This appliance must be installed and used in a sufficiently ventilated space only.

Familiarise yourself with all instructions before commencing with installation and use of this appliance.

This appliance must be registered once commissioned with the appropriate regulatory governing body.

This appliance is free from any asbestos material. Refractories and coal bed are constructed from ceramic fibre.

Note - For Republic of Ireland, reference should be made to the relevant standards governing installation, particularly regarding flue size and ventilation. See IS813, ICP3, IS327 in addition to any other rules that may be in force at the time of installation.

Section 2: INSTALLATION REQUIREMENTS

This appliance MUST NOT be installed in a bathroom, shower room or where steam may be present.

An extractor fan must not be fitted in the same room or space as the appliance as this can affect the safety of the appliance.

This appliance has been designed to fit into a fireplace or builders opening meeting certain dimensional requirements, or a suitable flue box complying with the constructional requirements of BS 715.

A natural draught flue system is required, and if previously used for solid fuel or oil burning, the flue and chimney must be swept prior to appliance installation.

The flue must be checked prior to installation by using a smoke pellet to ensure proper draw and that leakage is not evident at any joints. Repair and re-test as necessary before installing the appliance

Flue boxes must be installed onto a suitable non-combustible insulating surface at least 12mm thick, covering the entire base area of the box.

The flue must have an effective height of at least three metres, as measured from the hearth to the top of the flue.

Flue damper plates or restrictors must be removed, and no other restriction fitted to the flue. Where removal is not practical, the restriction must be fixed in the fully open position.

The flue must be connected to only one fireplace, and the flue must not vent more than one appliance.

There must be no opening in the flue apart from the one that the appliance is installed into, and the one venting the gases into the air. A suitable terminal may be fitted, such as class GC1, as regulations allow.

In accordance with BS1289 part 1, pre-cast flues built with directly plastered faces (front or rear) are not correctly installed as to ensure proper operation with any type of gas fire.

Depending on the flue construction, on occasions the temperature reached can cause cracking of the surface plaster through no fault of the appliance.

An air gap or suitable insulation material should be installed to prevent normal flue temperatures from damaging wall surfaces.

This appliance is suitable for use with a surrounding area or back panel of 150C minimum rating.

Section 3: APPLIANCE INFORMATION

Series 8000

Gas Group

G20 Natural Gas CAT I2H

Inlet Pressure	20 mbar
Max Input (gross)	6.2
Min Input (gross)	3.4
Setting Pressure	20 mbar
Gas Inlet connection	8mm Compression
Overall Height	532
Overall Width	1022
Overall Depth	322
Recess Height	460
Recess Width	875
Recess Depth	300
Air Vent	N/A*
Remote Valve	TESCO01 RF868-15
Remote Pilot Assembly & Thermocouple	OXPG-82-650
Slide Valve	TESA3173/011
Pilot Assembly & Thermocouple	OXPG-82-460
Spark Generator	YD9-1D
Injector Stereomatic	440
Efficiency	74.1% Net class1 66.8% Gross
NOx	Class 3
Appliance Dimensions	H532 x W1022 x D322
Appliance weight	45kg

***Not normally required but may be required following spillage test see section 13**

Section 4: VENTILATION

This Appliance does not normally require purpose provided ventilation. However, a second appliance operating within the same room or space must be taken into consideration when assessing ventilation.

When commissioning the appliance spillage is detected, then amongst other problems there may be insufficient natural ventilation for correct operation of the flue. If spillage is detected with windows closed, but the appliance does not spill with the windows open, this demonstrates a lack of natural ventilation.

If spillage is still detected with the windows open, the flue is at fault. Installation of an air brick is the best solution to lack of ventilation.

Any ventilation fitted must comply with BS 5871 part 2 and BS 5440 part 2.

Air Vents fitted under or within the immediate vicinity of the appliance must not be used as adverse effects to the operation of the Flame Safety Device (FSD) may occur. Spillage detected during commissioning is almost always a result of poor flue performance that cannot be corrected by any amount of ventilation.

For Republic of Ireland ventilation may be required, see IS 813, ICP3, IS 327, and any other rules in force.

Section 5: SITE REQUIREMENTS

The fireplace opening is to be inspected and repairs made where necessary.

The dimensional requirements for debris collection space and spigot clearances must be met. See diagram below.

This appliance requires a natural draught flue system which may be one of the following:

- 225mm x 225mm (9in x 9in) brick or stone
- 125mm (5") Minimum diameter flexible flue liner conforming to BSEN 1856-2
- 125mm (5") minimum diameter twin wall flue conforming to BSEN 1856-1: 2009

A minimum of 600mm flue height from the appliance is required before any bend in the flue, no bend greater than 45° must be used.

The area immediately above the outlet must form a smooth path into the flue.

Any existing draught device situated under the fireplace must be sealed off. The opening area must be non-combustible, for low height properties such as bungalows a spinning cowl or similar device may be recommended to help induce the correct pull from the flue.

It is recommended that a tactile barrier should be placed on the floor in front of the appliance to stop the elderly, infirm or Children from direct contact with the hot surfaces of the appliance.

The appliance can only be used in a no hearth application if the installation complies with BS 5871-2:2005 and appliance is installed so that the height from the base of the fireplace opening to the floor is no less than 300mm.

From the appliance to underneath of a Shelf with a depth of 150mm is 350mm add 12.5mm in height for every 25mm increase to the projection of the shelf depth.

Frameless option

If you are plastering the appliance in then you will need to remove the plaster from the wall around the fire enough to be able to fix a sheet of master board or non-combustible board over the fire box when in

place to be able to be plastered to a finish ready to be decorated, you can surface fix if you wish to use non-combustible slips such as granite, stone or marble, around the appliance.

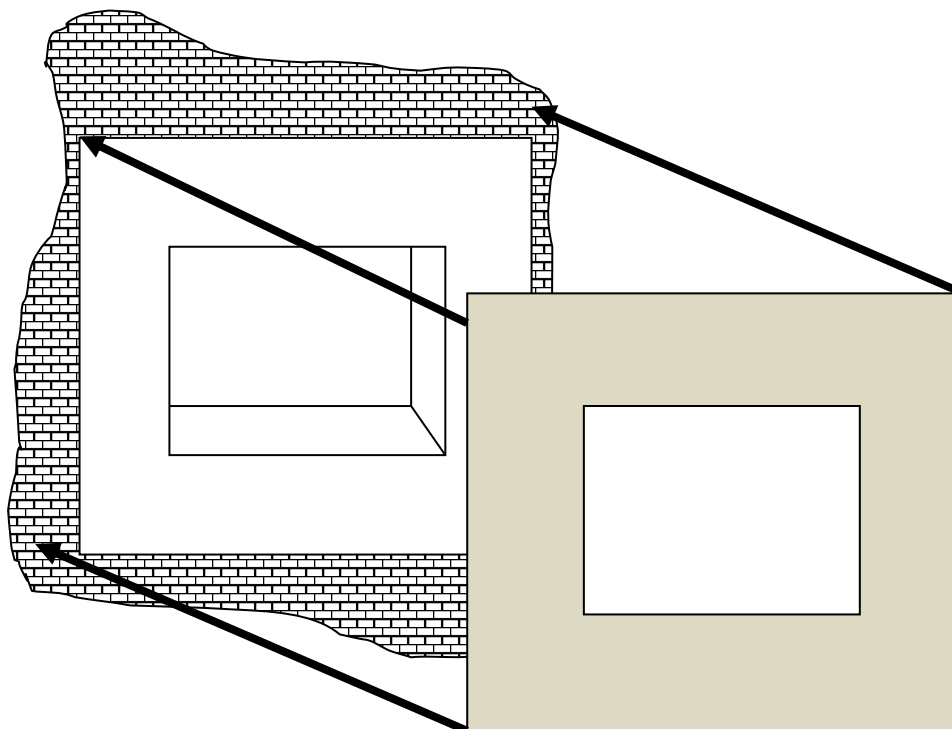

As with all heating appliances, any decorations, soft furnishings, and wall coverings (i.e. flock, blown vinyl and embossed paper) positioned too close to the appliance may discolour or scorch.

Due to the high efficiency of this type of appliance combined with the variations of plaster conditions and thicknesses from property to property, we recommend that a heat proof plaster be used.

An area of 600mm above plus 300mm on either side and below should be finished with a heat proof plaster, it may be required to use a heat proof screed under the finish, please see contact details below of possible supplies of these goods for your reference.

The Greener Company

Huddersfield Road, Elland, WEST YORKSHIRE HX5 0EE
www.thegreenercompany.com

Vitcas

8 Bonville Road, Brislington, Bristol BS4 5NZ
<http://www.vitcas.com>

Opening Requirements		MM
A	Width	875-895mm
B	Height	460-470mm
C	Depth	300mm

D	From Floor	300-450mm
---	------------	-----------

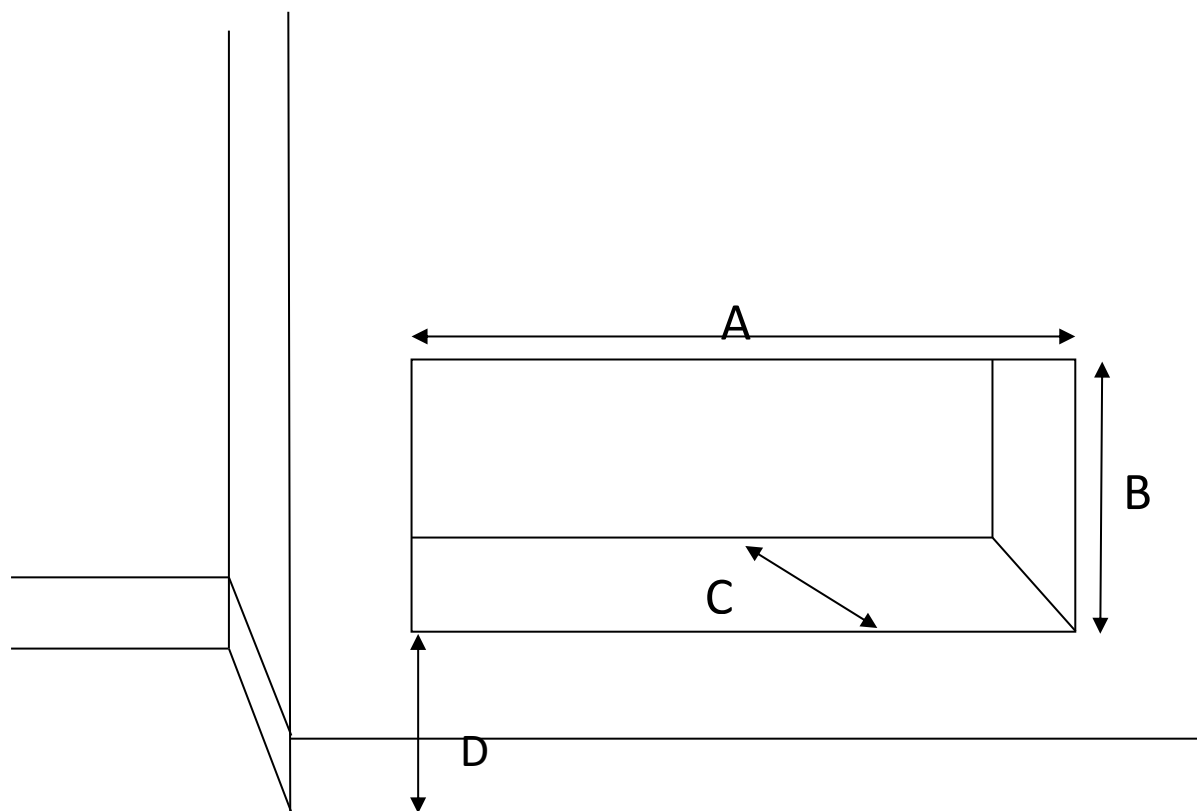

Section 5.1: PREFABRICATED FLUE BOXES

These appliances can be fitted to a prefabricated flue system, can be fitted directly to the appliance via the flue adaptor.

All will require a false chimney breast in which to be housed and will need to be constructed of a non-combustible material or any combustible material within 350mm must be clad with a non-combustible board.

The correct clearances to combustible materials (i.e., false chimney breast etc.) must be adhered to.

The manufacturer of the prefabricated box's instructions for fitting the prefabricated box must be always complied with.

Please ensure the firebox does not obscure the flue box outlet.

It is important that the sealing requirements of the appliance are always met, and that the flue box is sealed to any back or infill panel.

Section 6: CLEARANCES / DEBRIS SPACE

Appliance requires a minimum of **50mm** clearance (BS 5771: part 2-11.6) to the flue or any surface behind the appliance outlet.

In accordance with BS 5871 part 2, minimum debris collection volumes are required behind the installed appliance.

UNLINED FLUE OR CHIMNEY WHICH HAS BEEN PREVIOUSLY USED FOR A SOLID FUEL OR OIL BURNING APPLIANCE

Appliance recessed depth + 60mm

Section 7: INSTALLATION OF THE APPLIANCE

Always ensure that the gas supply is isolated before commencing installation of the appliance.

The fireplace opening and environment must follow specifications laid down in the appropriate sections of these instructions.

Remove the appliance from its carton as described previously and stand on a dust sheet, place the coals, ceramics and fixings safely to one side.

Remove the burner from the assembly by using a **hand-held screwdriver** remove the 4 x Screws at the top of the glass panel, with the glass door dropped down you can lift the door off its hinges to allow ease of access to the fire box and the burner, start by removing the ceramic pads over the burner and gently put this to one side to avoid any damage.



Next remove the screws in each corner and the one holding down the access panel,

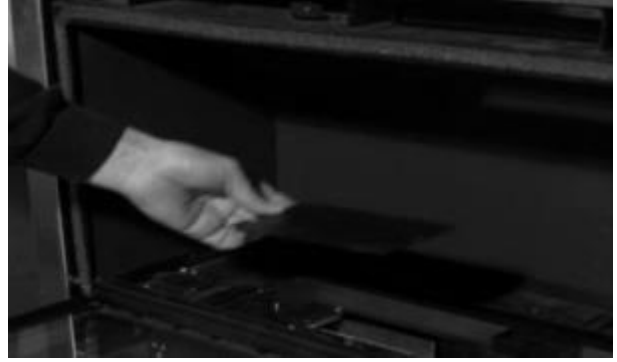

Next undo the nut connecting the burner to the isolation valve and tray will now lift free of the firebox.



If you are to use with a suite or as a frameless option then the Isolation tap needs to be repositioned.

Burner tray showing standard bracket



Burner tray with frameless bracket option

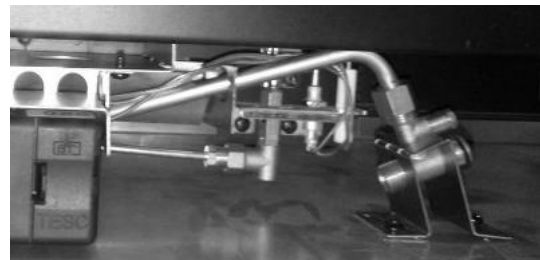

1. Remove bracket and retain the screws
2. Fold the new bracket to the shape shown Fig 1
3. Fit the bracket using the new location holes as below
4. Fit the isolation valve to the bracket

Use these for location of bracket

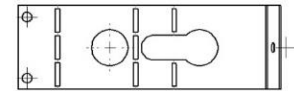
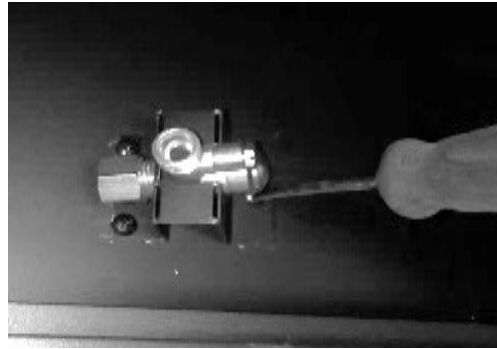
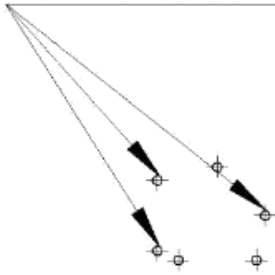

Fig 1

Section 7.1: PREPARING THE OPENING

Before installing the fire, check the flue for correct operation using a smoke pellet, all the smoke should be drawn up the flue and exit correctly from the terminal. If problems are found **DO NOT** fit the fire until corrective measures have been completed.

Section 7.2: ADAPTING THE BOX FOR FLUE LINER

At this point if required you can make some changes to the firebox to accept a flue liner.

First you must remove the flue restrictor plate at the back of the fire and replace with the flue closure plate supplied.

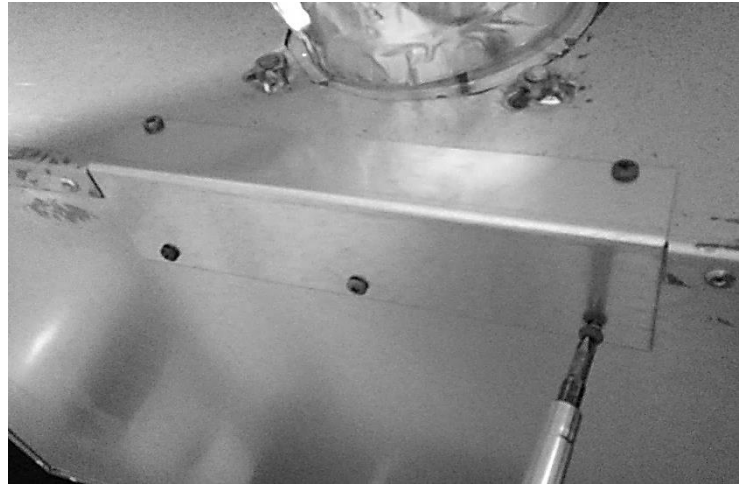
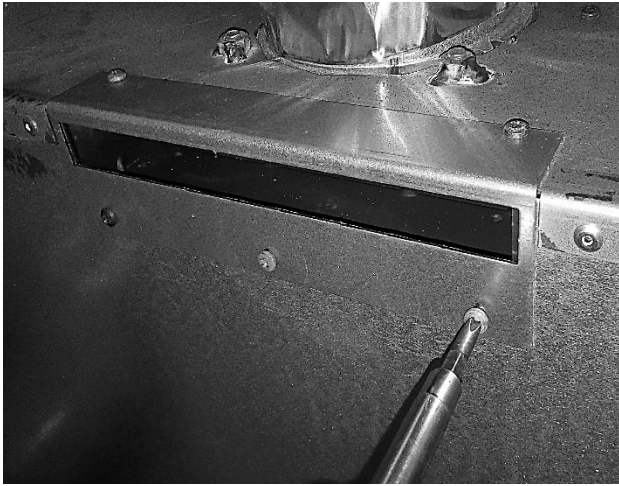

Next remove the top internal diverter plate from the top of the appliance by unscrewing the screws holding either side of the box keeping the panel in place.



Remove the second plate, exposing the opening, at this point fix the fire box into place and pass the liner through the opening in the box, connect to the flue adaptor supplied, to the liner using self-tapping screws and aluminium sealing tape (not supplied) push back up into position and fix the plate into place. Place the first plate back into position and secure internal diverter plate back into place by securing into position.



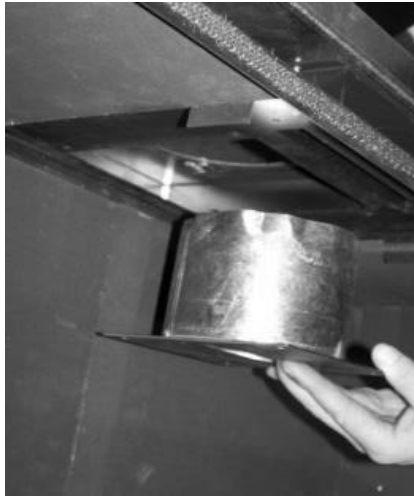

Section 7.1: PREPARING THE OPENING Cont.

Before running the gas supply into the opening, offer up the fire box to the fireplace to check the fit is good, ensure that it slides in correctly, the sealing face sits flat and square to the wall and that the base is level, apply the self-adhesive sealing strips around the edge of the rear of the firebox frame, approximately 5mm in from the edge.

Mark and drill the fire frame in the relevant 4 points on the wall and place Rawlplugs in place, alternatively you can use the tensioning cable fixing kit supplied (see separate fixing instructions with the kit)

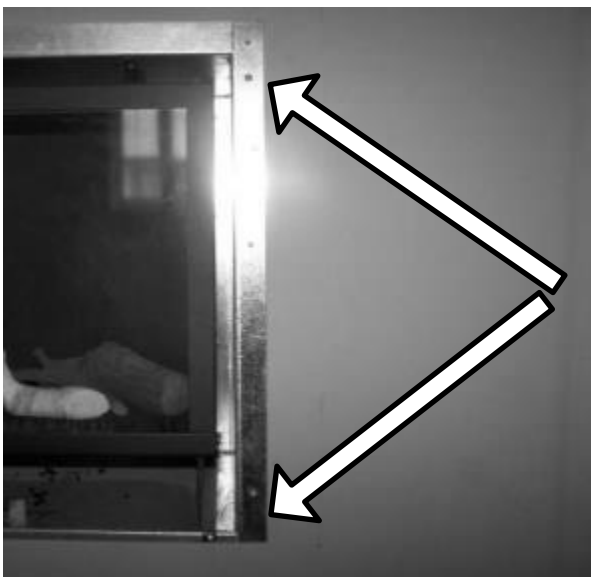

Note: Fibre Rawlplugs might be preferred rather than plastic Rawlplugs as the heat from the fire might affect their efficiency.

Whilst the opening is ready for installation of the fire, the gas supply can be routed and when in the correct position can be connected to the isolation tap via the 8mm compression fitting.

With the frameless option a power lead needs to be routed through a conduit or sleeved into the opening and into the fire at the rear, taking care to keep the cable, as shown in the diagram below ensuring that it is lying flat and away from the hot surface of the burner and components.

Frameless options must only use mains power and batteries must **NOT** be used.

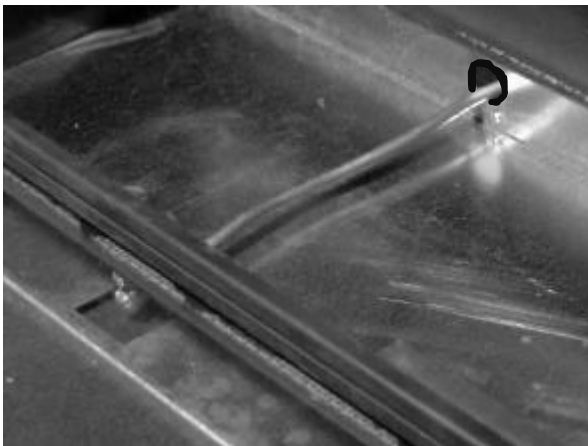
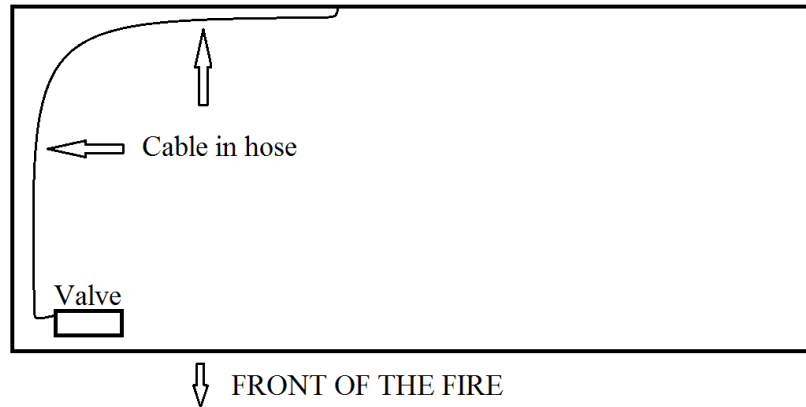

- DO NOT install or use the appliance without this seal in place.
- Failure to fit this seal correctly will cause the flue suction to act upon the area under the burner tray resulting in poor performance and overheating of this area.
- In no circumstance should you use soft soldered connections to or underneath the burner tray.
- The gas pipe must be suitably protected where it passes through fireplace openings. Any sleeving should be sealed to the pipe at its end.
- Fit all grommets supplied into inlet options where required. (including non-used openings)

Section 7.3: FITTING THE BURNER TRAY

Prior to the tray being placed in position if being used with a frameless kit then a manual override kit needs to be fitted.

1. Place the screws into the holes of the key mechanism and fix to the bracket on the remote-control valve

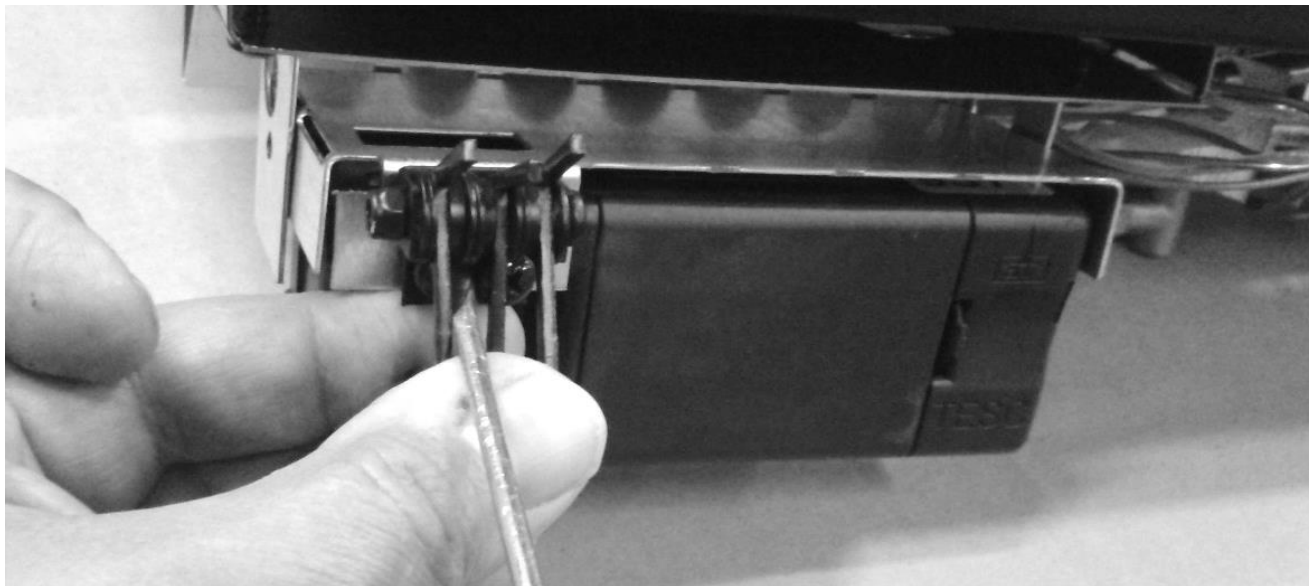

When fitting the frameless back panel with this installation ensure the keys fit above the panel as shown in Fig 2



Fig 1

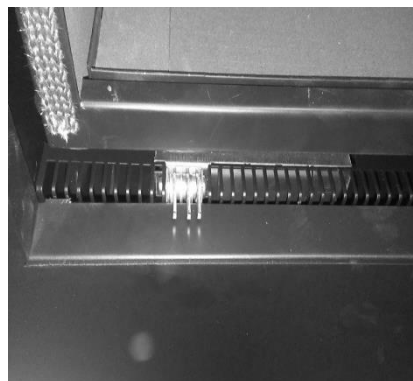
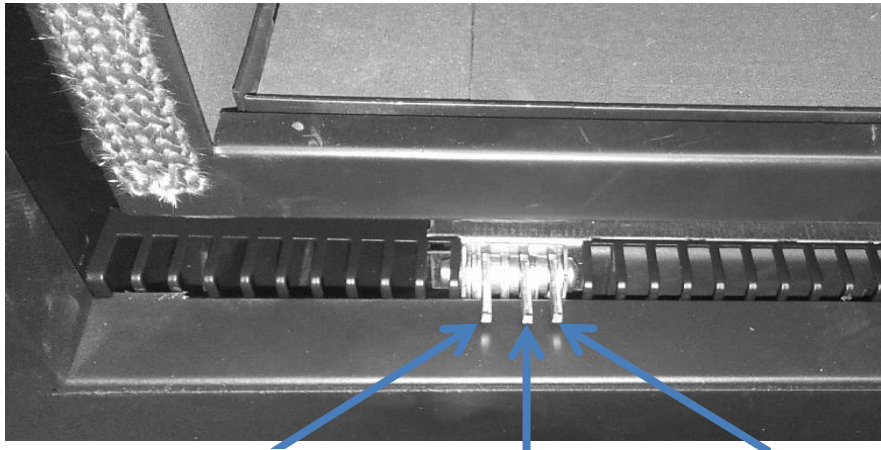

Fig 2

Now you can fit the tray with or without the frameless kit, reverse of the previous instructions on how to remove the burner tray.



Press to Decrease flame

**Power
Button**

To Increase Flame

The key mechanism will now give you manual control of the remote valve as shown above

The keys have a small movement of approx. 1mm.

The tray may now be placed into position reversing the removal instructions taking care with all ceramic parts.

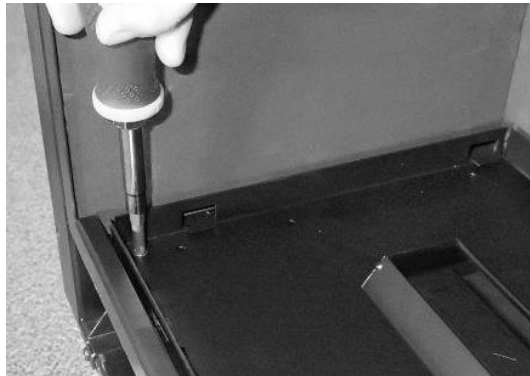
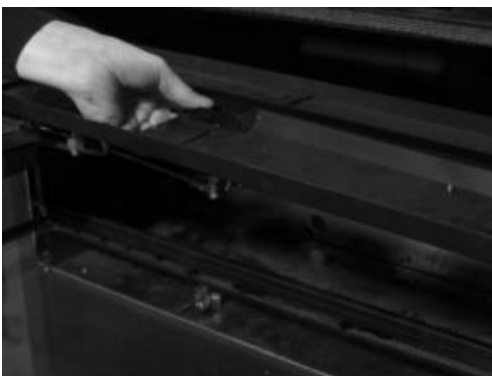

At this point if you have the slide controlled version then you can place the slide control piece in position using the two screws supplied.



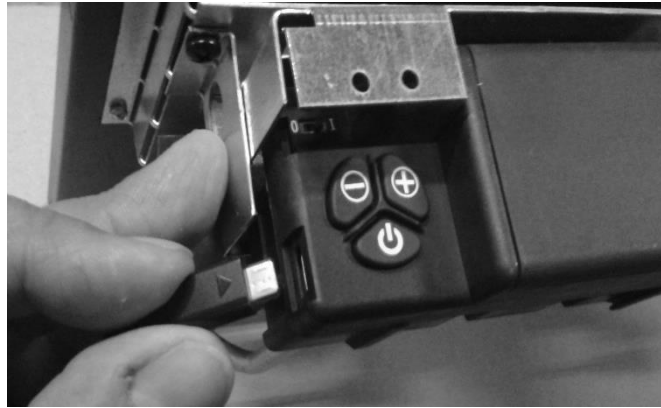

The power supply cord should be connected into the USB socket on the side of the remote-control valve ensuring the cord is routed away from any hot surfaces and the grommet provided is used to prevent chafing to the cord when passing through the fire box with the gas inlet pipe.

WHEN FIXING THE GLASS BACK INTO POSITION PLEASE PUT ALL THE SCREWS IN HALFWAY AND THEN TIGHTEN FULLY INTO PLACE TO AVOID TWISTING THE FRAME

With the burner tray fixed in place the sub frame for the frameless can be fitted as shown below, care must be taken to get this into the correct position as you can see in Fig 3 the bottom area of the subframe sits level to line up the manual control mechanism and the heat outlet at the top has a clear area see Fig 4.

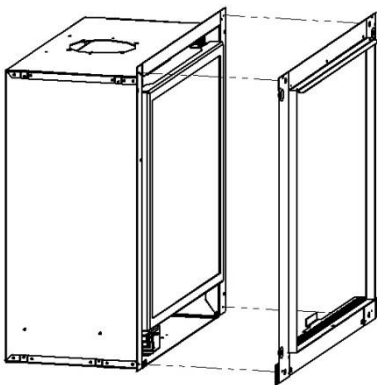

Fig 1



Fig 2

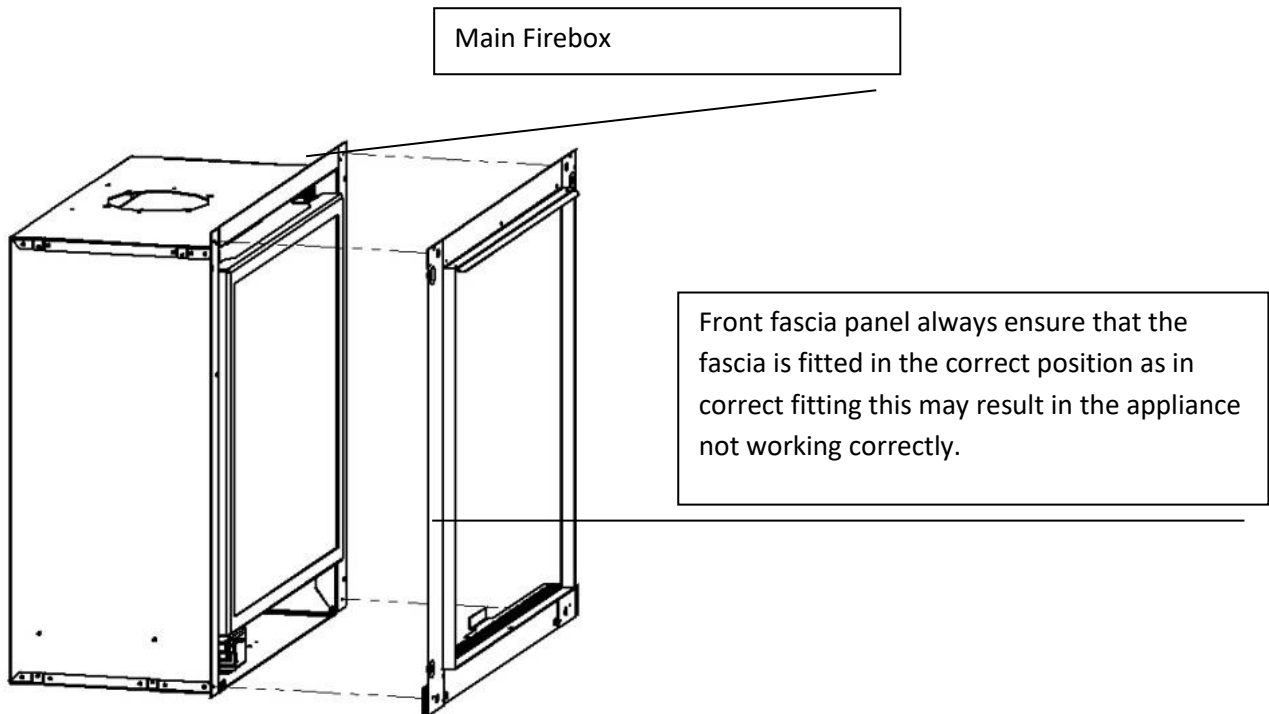

Fig 3

Fig 4



When using the appliance in conjunction with a fireplace suite, you can use either non-combustible slips like stone granite or marble, or a sirocco metal back panel, please see www.siroccofires.com for further details on the metal back panel.



Section 9: FITTING THE DECORATIVE FRAME

Fit the two brackets supplier to each side of the firebox with self-tapping screws supplied the simple lift the trim into place.



Section 8: FUEL BED LAYOUT and LINING REPLACEMENT

Please refer to the instructions supplied separately with each fuel bed option to remove the lining for colour change or replacement, simply with the tray removed the top place can be removed by the two brackets in place then gentle remove the side sections and the back to fit simply reverse the process.

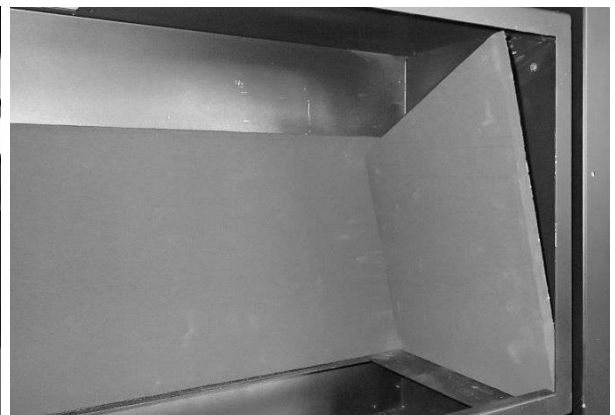



Instructions supplied separately with each fuel bed option.

WHEN FIXING THE GLASS BACK INTO POSITION PLEASE PUT ALL THE SCREWS IN HALFWAY AND THEN TIGHTEN FULLY INTO PLACE TO AVOID TWISTING THE FRAME

Section 10: COMMISSIONING THE APPLIANCE

Turn on and test the gas supply up to the fire for any leaks, in accordance with current Approved Codes

Section 10.1: OPERATING THE APPLIANCE

(See Section 16: Users Instructions)

Section 10.2: SPARK FAILURE

The gap between the spark electrode and the pilot should be 3.5 - 4.5mm to produce a good spark. There should be no need to adjust this.

If under any circumstances the electric spark fails, the pilot may be lit manually by proceeding with the ignition sequence as previously described, and after turning the control knob through the spark position, the knob should be held in and the pilot lit with a taper.

Note: Please ensure that the electrode spark igniters' gap on the manual version has not been misaligned during the handling of the burner in this installation the gap should be 5mm from the burner.

Section 11: SETTING THE GAS PRESSURE

Remove the pressure test point sealing screw from the isolation elbow and attach a suitable pressure gauge.



Check that the inlet gas pressure is at 20 mbar / Working Pressure at 20 mbar (+/- 1 mbar)
Light the pilot and check the correct operation of the burner at all the flame settings.

Always check that the gas has stopped flowing even if you hear the FSD valve close within the 3-minute period.

Turn OFF the appliance and the gas supply and refit the pressure test point sealing screw.

SECTION 12: FLUE SPILLAGE MONITORING SYSTEM

This fire is fitted with a flue spillage safety device (ODS), if the fire shuts down during use for no apparent reason, then several things may be suspected, if a door or window has been opened creating a draught, then pilot disturbance is the problem, and removal of the draught should resolve this.

The gas pressure reaching the fire must also be checked (again, recalls your installer to check and rectify any problem). The thermocouple connection into the back of the gas control valve may also have worked loose during installation, simply get the installer to tighten.

If pilot disturbance is not the cause, then the ODS safety system may be in operation. Switch the appliance OFF, check the flue and carry out any remedial work required. Relight the fire and carry out a spillage test, DO NOT allow the appliance to be used if it continues to fail a spillage test.

The aeration hole of the pilot must be carefully cleaned out on each annual service to ensure continued function of the ODS.

The spillage monitoring system shall not be adjusted, modified, or put out of operation by the installer. Any spare parts fitted MUST be of a type supplied for the purpose by the appliance manufacturer. If the fire is not spilling, then further guidance should be sought, using the Troubleshooting section as a guide.

SECTION 13: TESTING FOR SPILLAGE

CHECKING FOR CLEARANCE OF COMBUSTION PRODUCTS

Close all doors and windows in the room light the fire and allow to run for approximately 5 minutes on high position.

After approximately 5 minutes, hold a smoke match just inside and below the centre of the lower front edge of the top of the fire, as shown below in Fig 1.

All smoke generated should be drawn back into the flue, if slight spillage occurs or if in doubt, repeat the test after a further 5-10 minutes. If the test indicates that spillage is occurring and the flue restrictor baffle has been fitted, it should be removed and the test repeated after the fire has cooled, if spillage persists, the flue is not functioning correctly, and a fault exists.

If, after investigation the fault cannot be traced and rectified, the fire must be disconnected from the gas supply and expert advice obtained.

After ensuring that the fire is safe to use it should be left on high position to fully warm up. During this time, a slight odour may be noticed, this is due to the "newness" of the fire and will soon disappear.

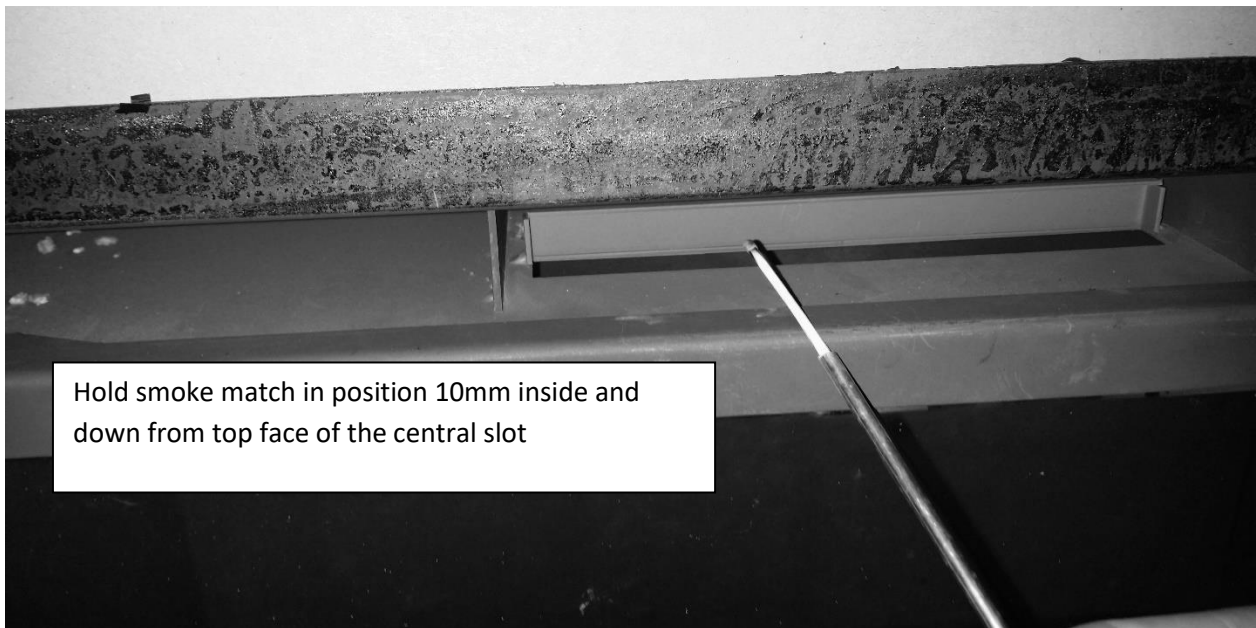

Fig 1

When the test has been completed satisfactorily, repeat with any extractor fans in the premises running on the highest setting, and any communicating doors open, finally, repeat with all doors open.

DO NOT allow the fire to be used until the test is satisfactorily passed.

SECTION 14: BRIEFING THE CUSTOMER

- All instructions must be handed to the user for safekeeping.
- Show the customer how to light and operate the fire.
- After commissioning the appliance, the customer should be instructed on the safe use of the appliance and the informed for the need of regular servicing.
- Frequency of service depends on usage but **MUST** be carried out at least once annually.
- Cleaning of the fire may be achieved when the fire is cold using a damp cloth and mild detergent on most surfaces, except for the ceramic fuel bed.
- A soft brush i.e., paint brush may be used to clean the ceramic fuel bed taken care not to use excessive pressure.
- Scratched and other superficial damage to the matt black paintwork of the appliance can be covered with matching heatproof spray.
- Use only the manufacturers' recommended spray paint.
- Paint only when the fire is OFF and cold. Always mask off the surrounding area to prevent contamination with overspray.
- Ventilate the room during the use of the spray. DO NOT attempt to spray paint the coals or ceramics or wash them in water.
- Advise that the fire will emit a "newness" smell for a time after initial commissioning and that extra ventilation may be needed during this time.
- Advise that the fire is fitted with a spillage safety device (O.D.S.). If the fire shuts down, this system may be in operation.

If spillage is suspected, SWITCH APPLIANCE OFF and call in the installer to investigate any problems.

SECTION 15: SERVICING

First Isolate the fire from the gas supply and ensure that the fire is fully cold before attempting service.

- Lay out the dust sheet and tools required.
- Remove Trim and Glass if applicable.
- Carefully remove the ceramic components
- Remove the screws that retain the tray in place and disconnect from the isolation tap.
- Remove the burner tray and other components as required (i.e. remote control box)
- Disconnect the gas supply, to the appliance and disconnect the isolation tap
- Remove convector box, Check the fireplace opening for rubble accumulation and remove, if debris is excessive, and initiate remedial work on the flue.
- Check the flue with smoke pellet for correct operation.
- Refit convector box using new seals where necessary
- Strip off the burner pipes and clean thoroughly.
- Clean out the injector, pilot assembly and burner tube. DO NOT remove the pilot injector.
- Re-assemble and re-fit the burner tray.
- Turn on the gas supply, and leak test.
- Refit the decorative casting and ceramics.
- Check any purpose provided ventilation is un-obstructed.
- Light the fire and test for spillage.
- Check setting pressure and safe operation of the appliance.

SECTION 16: USER INSTRUCTIONS

IMPORTANT NOTES

The installation of this fire **MUST** only be carried out by a competent person (such as a Gas Safe registered fitter) in accordance with the Gas Safety (Installation and Use) Regulations 1998, the relevant British Standards, Codes of Practice, the Building Regulations and the manufacturers' instructions.

- Failure to comply with the above recommendations could lead to prosecution and invalidate the appliance warranty.
- Please ensure you are handed all the manufacturer's documents on completion of the installation. This will include these instructions.
- Always keep a note of the installer's name and address, the original purchase receipt and the date of installation for future reference.
- The fire and flue should be serviced regularly to ensure continued safe operation.
- See the servicing section for further details.
- Frequency of service will depend on use but **MUST** be carried out at least once annually.
- Parts of this appliance become naturally hot during use.
- It is recommended that a suitable fire guard conforming to BS8423 is used, especially where young children, the elderly, or infirm are concerned.
- Combustible items, such as flooring and furniture, and soft wall coverings (such as blown vinyl or embossed paper) may discolour if fitted too close to the fire.
- See relevant section for further details on clearances to combustibles.
- No combustible material or flooring should protrude onto the hearth.
- **DO NOT** burn any foreign material on this fire, the coals must be of the correct type and lay out in accordance with the relevant section of these instructions.
- Failure to do so could create a hazard or lead to sooting.
- Before the appliance is installed, the chimney should be swept.
- All flues should be checked by the installer to ensure there are no defects or obstructions that may prevent the flow of combustion products.
- The fire is only suitable for use with the gas type for which it is supplied.
- This fire is supplied with a particular style of fire front/fret.
- Use of the fire front/fret will ensure an adequate airflow under the fire bed for the correct functioning of this appliance.
- Compliance with safety standards cannot be guaranteed if another style of front is used.
- A combustible shelf may be fixed to the wall above the fire, providing that it complies with the dimensions given in section 3 site requirements.
- No purpose provided ventilation is normally required for this appliance.
- The requirements of other appliances operating in the same space or room, and the results of a spillage test must be taken into consideration when assessing ventilation requirements; this will have been carried out by your Gas Safe registered installer.
- Do not operate this appliance if the glass door is broken, removed or open.

The appliance is fitted with an atmospheric sensing device designed to shut off the fire in the event of the flue being partially or completely blocked causing a build-up of combustion products in the room that the appliance is operating, if the fire repeatedly turns itself off then contact a gas safe installer to investigate the fault.

For Republic of Ireland, ventilation may be required, see IS 813, ICP3, IS 327 as appropriate

SECTION 17: OPERATING THE APPLIANCE (Remote Control)

The Remote Control with this appliance has already been paired at the Factory

Quick start user instructions

Fire Control

This control is situated on your fire. The drawing shows the main features of the control.

The control required **3 x AA size alkaline batteries** to be inserted under the battery compartment cover.

The orientation of these is shown moulded into the battery compartment.

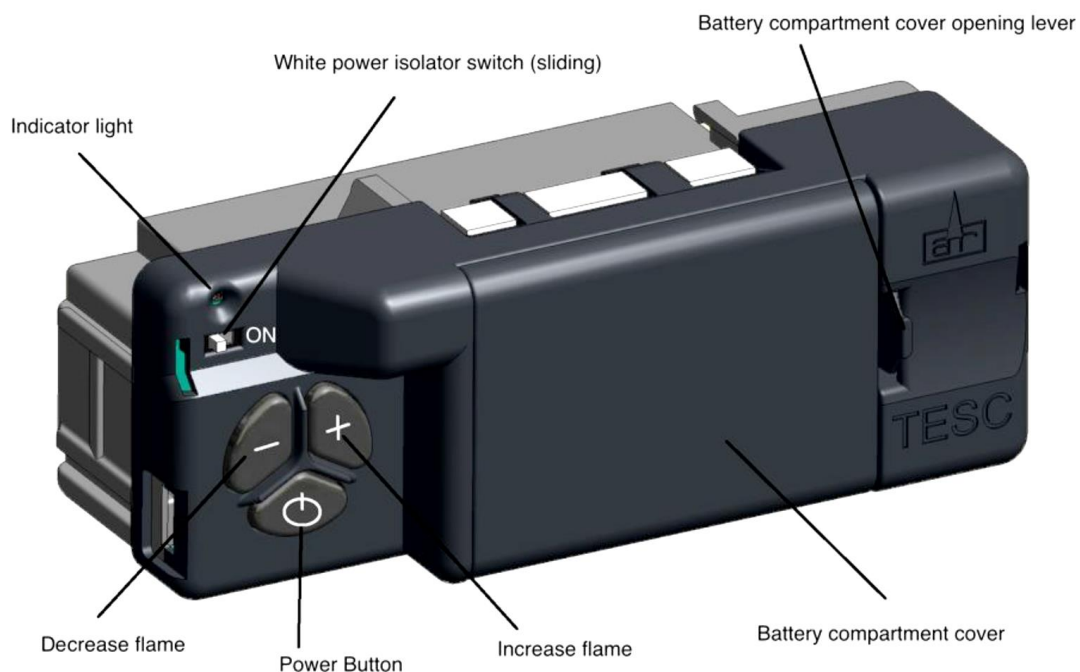

After fitting the batteries and replacing the cover the fire can now operate. Slide the slide switch to the right to the ON position.

To start the fire, press the power button and hold for 1 second then release. The burner will within around 1 to 2 seconds, adjust to the maximum power setting,

The power of the burner can be adjusted up and down by pressing the – or + buttons.

To stop the fire, simply press the power button again and the burner will stop.

If you are not intending to use the fire for a long period (i.e. over summer time months), the battery life can be extended even more by sliding the white isolator switch to the left (away from the on position).

Ensure the very small white slider switch on the front corner of Fire Control is in the on position.

Grasp around the handset to unlock its functions. The green unlock light will illuminate to show when the handset is unlocked and ready to accept commands. (N.B. Keep a grip of handset to keep it unlocked, to continue to operate the command buttons.)

For your safety, the fire is fitted with a Flame Supervision Device (FSD), which will shut off the Gas supply if for any reason the pilot is extinguished.

The Valve and Handset Have Already Been Paired

First set up the handset, cup the handset **the green unlock light will illuminate**. Keep it held to keep the control unlocked, to enable operation of the buttons.



3) Setting the time, the display will be as shown, as the time is not set yet and will progress automatically to the next screen shown below.



Note: the indicator at the bottom shows the battery condition of both the batteries in the hand set and in the fire control within the fire.

RC = Remote Control / FC = Fire Control.

The control is designed to get the most out of the batteries but when eventually the display shows they are spent (when the battery indicator is empty, we recommend you change the batteries in the handset before they are flat, to avoid having to re-program the time of day in again. N.B. Pairing is not lost, even if the batteries are removed or flat.

4) Setting the display for 12- or 24-Hour display

As always when pressing the remote-control buttons keep the control held to keep the green light on and therefore handset safety feature, unlocked. The H indicates that it is time to set the timer to either 24-hour display or 12 Hour (AM or PM) display. Press the + or – button on the handset to toggle between the two settings. When you are ready to confirm the setting, you want press the “SET” button to progress to setting the day of the week.



Setting the day of the week

Press and release the + and – buttons until the correct day of the week is shown on the display.

(Mo = Monday, Tu= Tuesday, We=Wednesday, Th=Thursday, Fr=Friday, Sa=Saturday and Su=Sunday).

Press “SET” to accept the day of the week and to progress to setting the Hour of the day.

Note: Whilst doing this setup pressing “SET” advances to the next display and pressing “MODE” will return you to the previous display setting.



Setting the Hour

Press and release the + or – button to change the hour to the correct hour and press set to store and to move to setting the minute. Repeat this for setting the minutes.



Setting the temperature display to Celsius or Fahrenheit.

Press and release the + or - button to toggle between C and F.

When the display shows the desired symbol, press and releases the "SET" button to store.

As the important settings above have now been done. Press and hold (not releasing straight away) the "SET" button for a few seconds and this will exit the setup menu.

The control is now ready for use with the Fire Control.



Quick start user instructions

First set up the handset, cup the handset **the green unlock light will illuminate**. Keep it held to keep the control unlocked, to enable operation of the buttons.



Then with the other hand touch and keep you finger on the power button for about 5 seconds. (Upon touching the power button, the green light will do a **single flash** to show command is recognized – after 5 seconds the green light will flash for a second time, at which you should release your finger). The Fire should be lit within a few seconds. (N.B. If power button is held for more than a few seconds after second flash/beep, the command ignored for safety reasons. With this system, the control has been designed to ensure that only intended ignition of the fire occurs.) To stop – with handset held to unlock it, press then release power button.

Mode
Man = Manual
Zzz = Snooze
Therm = Thermostat
Timed

In Range of the fire
If missing out of range or fire switched off

Day of the Week

Time (12 or 24hr)

Fire Status

Battery Indicator
RC = Handset
FC = Fire Control

Light Sensor (for Display Backlight)

To Change Mode

Press to Decrease

Power Button



Room Temperature

Handset Unlocked if Illuminated

To Change Settings, see handbook

To Increase Flame

Operating instruction (Detailed)

1) Upon successful insertion of the batteries in the Handset (if the handset has not previously paired) the display will be as shown if it has been paired already then go to No 3.



1a) If display is not as above the handset may well need to be reset before pairing. Press and Hold "Set" Button, to enter Programming menu When Set Up is flashing, press and release set to enter Setup Mode.



Press and Release the "Set" button several times until you see CAO displayed. Then press and release "+" button once to change display to CA1 Press and Release the "Set" button once more to display TESC, handset is now ready to pair.

2) Pairing the Handset to the Fire Control

After fitting the batteries as above (and with the isolator slide switch on the TESC Fire control in the ON position), simultaneously press and hold the – and + buttons on the fire control (i.e., not the handset) until the handset makes a noise and the display shows the pattern as shown here.



Hold the handset in one hand so your fingers wrap around the back of the operating buttons area of the handset. A green unlock light will illuminate when the handset has detected your hand. The green light must be illuminated in this way for any of the command buttons to accept commands to operate the fire control. Whilst the display is as shown, and holding the handset as described, press the "SET" button with the other hand to finish off the pairing of the handset to the Fire Control and to enter to setup the time of day on the handset. N.B. If the display returns to the one shown above with the word "TESC" shown, then too much time has passed before pressing "SET" and so the handset has not paired yet. Simply repeat pairing again.

Advanced settings Menu

If you may want to change the other pre-set settings of the control features. Do not do a long press and hold above but a normal short press and release will take you into the advanced settings area.

Advanced settings options are: -

- Back light –
 - o A = Automatic (default setting). The back light comes on in the dark but not in the light.
 - o 0 = Light never comes on.
 - o 1 = Light comes on whenever handset is unlocked.
- Display contrast – 8 levels from 0 to 7 (default level 4).
- P = pairing with other devices other than the fire control.

The handset can pair with other modules to: -

- o L= Operate an electric light – which is the dimmable in 9 steps
- o F= operate an electric fan –which can have 9 speed levels
- o A= operate an auxiliary contact to operate another device.

Note:

- ***Fitting the batteries incorrectly could lead to damaging your Valve.***
- ***Different types of batteries or old and new batteries are not to be mixed.***
- ***Only batteries of the same or equivalent type as recommended are to be used.***
- ***Batteries are to be inserted with the correct polarity.***
- ***Exhausted batteries are to be removed from the fire.***
- ***The supply terminals are not to be short-circuited.***
- ***Do not use rechargeable batteries.***
- ***Non-re-chargeable batteries are not to be recharged.***
- ***Do not mix old and new batteries.***
- ***Do not mix alkaline, standard (carbon zinc) or re-chargeable batteries.***

SECTION 17: OPERATING THE APPLIANCE (Slide Control)

1. From the standing position push the thumb control all the way to the right where a spark will be heard and generated, hold for approximately 15 seconds.



2. Release the pressure and the pilot light should now be established (if this fails repeat step 1 and hold down for 20 seconds).
3. Slide the control to the left to increase the flame size to the desired effect.

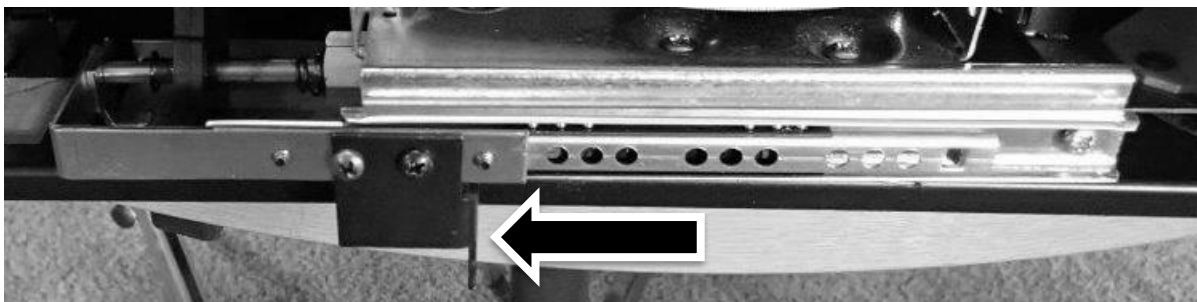

4. To switch the fire off simple, slide the control all the way to the left, passed the positive stop.

SECTION 17a: Remote Error Trouble Shooting Guide

<u>Code</u>	<u>Comment</u>	<u>Appearance</u>	<u>Possible Cause</u>	<u>Action</u>	
E00	TESC locked due to failed ignition	Red Led is permanently on TESC unit (and E00 on handset, if used)	Temporary air disturbance around pilot burner	Reset control by pressing start button for 1 second and releasing. The press again the same way to attempt a normal start command. Repeat up to 10 times as necessary to see if this overcomes the issue as it may resolve itself eventually.	
			No gas on appliance inlet	Check to see if gas is present at gas appliance inlet. (Check gas supply is on, the gas line purged of air and the supply pipework is free of blockages or contamination)	Rectify and perform start cycle to clear the Error code. Try to light the fire as normal.
			Pilot contaminated with lint or other materials	Clean the pilot fee of any dirt, dust carbon granules or lint, especially around the brass body of the Bunsen burner and its gas and electrical connection and the area around the flame ports and the spark plug and electrode tip. Check the electrode gap is 3- 4 mm.	Rectify and perform start cycle to clear the Error code. Try to light the fir as normal. Replace pilot if necessary
			No Spark at Electrode (fire not igniting pilot burner)	Check ignition cable for damage and listen and watch for tracking out of spark to see if it is present but not making it to the electrode tip on the pilot burner.	If cable damaged, replace cable. Reset error by performing a normal start cycle and try to start again. Replace pilot if necessary.
			Pilot pipe or pilot injector could be blocked	Clear pipe and consider changing pilot	
E01	Low current from thermocouple but flame: possibly CO alarm	Flashing Red LED on TESC Control	Pilot pipe blocked - no gas reaching pilot burner	Check pilot pipe, check flame appearance of pilot flames	
			Chimney blocked causing Co / Co2 to build up in the room	Check flue	
			Pilot thermocouple defective / old	Change pilot or thermocouple	
			Possible temporary air disturbance on pilot flame	Clear error and restart to check ignition ok	

Code	Comment	Appearance	Possible Cause	Action	
E02	too high ambient temperature (>73 °C) around control		Negative flue pull or blocked flue or similar	Occurs if started ok then subsequently loss of thermocouple current. Check for flue problems. Fire cuts out to prevent over heating	Reset and try again
			Blocked flue	Check and clear	Reset and try again
			Poor position of Ceramic parts	Check manual for correct placement	Reset and try again
E03	no, defective, or bad connected thermocouple		Bad connection	Check if connected are correct and terminals are sound	Reset and try again
			defective thermocouple	Replace Pilot	Reset and try again
E04	false flame signal		occurs during stopping fire	Sensing flame on pilot when no flame should be there. Investigate.	Reset and try again
E05	false flame signal		Flame sensing on pilot before start of ignition sequence or after valve has shut off. Contamination of electrode to ground	Check if and clean around the area of the pilot for lint and other contamination and clean. Check where the thermocouple connects to the TESC control for the same contamination. Clean these areas.	Reset and try again
E06	too low voltage on power supply to start the burner		Weak or old or defective batteries	Replace batteries	Reset and try again
E07	power supply breakdown during peak current consumption		Check/change all the batteries or check power adaptor.: Note always change all batteries together never only 1 or 2	Replace batteries / power adaptor	Reset and try again
E08	error caused by external pressure switch		Check the pressure switch	Replace if necessary	Reset and try again
	Jumpers on back of valve missing		Check to see if jumpers are in 10-way connector		Reset and try again
E09	error caused by external pressure switch		pressures switch action connection or jumpers missing or not connected properly	Check pressure switch connections, check to see if jumpers are in place on back of TESC.	Reset and try again
E10	error caused by external pressure switch		pressures witch action connection or jumpers missing or not connected properly	Check pressure switch connections, check to see if jumpers are in place on back of TESC.	Reset and try again

Code	Comment	Appearance	Possible Cause	Action	
E11	short circuit on wired thermostat (if used)		Check switch	Check switch for damage, contamination across terminals or damaged wiring. Disconnect wired thermostat if fitted and try a start, if it works replace thermostat	Reset and try again
E12	open circuit on wired thermostat (if used)		Check wiring and thermostat	Check switch for damage, contamination across terminals or damaged wiring. Disconnect wired thermostat if fitted and try a start, if it works replace thermostat	Reset and try again
E13	wired thermostat is out of tolerance		Check wiring and thermostat	Check switch for damage, contamination across terminals or damaged wiring. Disconnect wired thermostat if fitted and try a start, if it works replace thermostat	Reset and try again
E14	button (-) sticks either on TESC or on wired control panel (if used)		Check for contamination around buttons	Clean as necessary. Replace switch panel as necessary if damaged or too contaminated. Disconnect wired control panel and try again – if it works replace wired control panel	Reset and try again
E15	button (+) is shorted to other buttons either on TESC or on wired control panel (if used)		Check for contamination/ damage -	Clean as necessary. Replace switch panel as necessary if damaged or too contaminated. Disconnect wired control panel and try again – if it works replace wired control panel	Reset and try again
E16	button (ON/OFF) is shorted to other buttons either on TESC or on wired control panel (if used)		Check for contamination / damage and replace wired switch panel if necessary	Clean as necessary. Replace switch panel as necessary if damaged or too contaminated. Disconnect wired control panel and try again – if it works replace wired control panel	Reset and try again
E17	button (-) is shorted to other buttons either on TESC or on wired control panel (if used)		Check for contamination / damage and replace wired switch panel if necessary	Clean as necessary. Replace switch panel as necessary if damaged or too contaminated. Disconnect wired control panel and try again – if it works replace wired control panel	Reset and try again
E18	button (AUX) is shorted to other buttons on switch panel		Check for contamination / damage and replace wired switch panel if necessary	Clean as necessary. Replace switch panel as necessary if damaged or too contaminated.	Reset and try again
E19	Infrared receiver defective (if used)		Check connection of IR or damage - replace if necessary, IR eye	Check if wired correctly and replace IR eye if necessary	Reset and try again
E20	Incorrect setup parameters		Check connection of IR or damage - replace if necessary, IR eye	Check if wired correctly and replace IR eye if necessary	Reset and try again

Code	Comment	Possible Cause	Action	
E21	tried to config a TESC as Cluster slave while a wired thermostat is connected	Factory assembly warning on setup configuration not a maintenance error	Usually only a factory assembly error. Could happen if done in error in servicing.	Reset and try again
E22	tried to calibrate TESC with TESC easy test while a wired thermostat is connected	Not field error	Disconnect thermostat before attempting to use Easy test unit.	Reset and try again
E23	warning: end of life is near, should be replaced soon	Not field error	Indicated that control has performed a high number of operations and so fire should be serviced, and control replacement should be considered as preventative maintenance. (Should not really occur before 10 years from new, depends upon usage).	Reset and try again
E24	Thermocouple does not reach final current - damaged or aged	Replace Pilot	Check and correct Thermocouple wiring. Replace thermocouple if necessary	Reset and try again
		Check pilot connections	Check and correct Thermocouple wiring. Replace thermocouple if necessary	Reset and try again
		Pilot pipe may be blocked completely	Clear pipe, replace pilot as necessary	Reset and try again
E25	Poor thermocouple signal	Tired or bad connection of thermocouple or bad or unstable flame on pilot or poor grounding return	Check pilot thermocouple connections and connections to TESC	Reset and try again
E26	defective or wrong wired USB-power supply	try again and if repeatedly fails replace	Replace with new USB power supply of the correct type.	Reset and try again
E48	short circuit on thermocouple, or thermocouple reversed polarity	Wrongly wired	Check and correct Thermocouple wiring. Replace thermocouple if necessary	Reset and try again
E49	false flame signal	Flame detected during operation of fire when it should not be detected - contamination of electrode circuit to ground	Check if and clean around the area of the pilot for lint and other contamination and clean. Check where the thermocouple connects to the TESC control for the same contamination. Clean these areas.	Reset and try again
E50	internal error	Flame detected during operation of fire when it should not be detected - contamination of electrode circuit to ground	Check if and clean around the area of the pilot for lint and other contamination and clean. Check where the thermocouple connects to the TESC control for the same contamination. Clean these areas.	Reset and try again
E51	error caused by external pressure switch		Check pressure switch connections, check to see if jumpers are in place on back of TESC.	Reset and try again

SECTION 18: CLEANING THE COALS

- Open the glass door
- Remove the ceramic components.
- Gently clean in the open air using a dry paint brush.
- Be careful not to create dust from the ceramics.
- Where necessary replace damaged components with genuine spares.
- Seal scrap ceramic components in plastic bags and dispose at proper refuse sites as directed.
- Re-fit the ceramics by referring to the relevant section of these instructions.

GENERAL CLEANING

- Before carrying out any of the following operations, ensure that the fire is OFF and completely cold.
- Debris that may form on the fire bed should be periodically removed by a competent person. Large deposits could indicate deterioration of the flue. This should be repaired by a competent person, and the fire serviced before further use.
- FIRE FRONT/FRET - Any dust accumulating in the fire front may be removed using a vacuum cleaner or dry cloth. Heavy stains may be removed by using a damp cloth and mild household detergent.
- Brass parts of the fire front may be cleaned using a suitable brass cleaner.
- Replace the front centrally against the fire after cleaning.
- PAINTED AREAS - These can be cleaned using a dry cloth.
- GLASS - Remove the Glass panel as shown on page 10 and 11 please follow the instructions carefully and clean glass with a glass cleaner and a lint free cloth or Microsoft cloth, if white haze or carbon discolouration is still apparent a metal polish such as Hotspot or Peek can be used to remove these stubborn particles, **when securing the glass in place please secure all screw half way before fully tightening the glass to avoid twisting the glass door.**

SECTION 19: WARRANTY

IMPORTANT INFORMATION ABOUT WARRANTY SERVICE FOR THE END USER

WARRANTY REGISTRATION IS REQUIRED WITHIN 28 DAYS FROM DATE OF PURCHASE

It is in your interest to register your appliance with Sirocco as soon as possible

BEFORE CONTACTING SIROCCO FOR SERVICE PLEASE READ THE FOLLOWING;

Sirocco is committed to customer care and service. To ensure we provide the best service we can we have a policy to charge for all none warranty home visits so that all customers with a genuine manufactures fault can be dealt with swiftly, if your appliance has recently been installed and you are experiencing any of the following;

- Fumes are spilling from the flue/fire
- The pilot light cuts out after a few minutes
- The fire controls are getting too hot
- Excessive sooting is forming on the fuel bed
- Poor flame picture
- Remote controls are not working

These symptoms tend to be chimney/flue or installations related and as such mostly are not covered by your warranty and are mostly dealt with in the installation instructions, **DO NOT USE YOUR APPLIANCE** and in the first instance contact your installer to investigate these further, to establish their cause before contacting Sirocco.

CONTACTING SIROCCO FOR WARRANTY SERVICE OR TO PURCHASE SPARE PARTS

In the event of a service or parts claim please note that some parts such as **ceramics, batteries, trims and fronts** etc. are categorized as “user serviceable parts’ and are not carried out by a service visit.

Please ensure you have the following information at hand when you contact Sirocco;

- The full serial number which is located on the data badge of the appliance
- Your receipt of purchase showing the date and where it was purchased from
- Your installers detail

You can contact Sirocco`s representative in the UK by phone to obtain advice and a warranty service form on;

0843 289 0102

Or you can complete a form online at www.siroccofires.com

SIROCCO Sp. Zo.o Nad Lasem 8, Zelecow, 96-321 Zabia Wola, Poland. Tel 0048 22 425 8681, Fax 0048 46 857 8559.

Further information, contact details and email facilities are available through our website; www.siroccofires.com

SECTION 20: LIST OF SPARES

Code	860 HE Spares	PART NUMBER						
	Replacement glass panel with door	PRT	GLA	SIR	86	BL	FR	1
	Engine (remote) Excluding ceramics with Handset	PRT	VOL	86	N	RC	ENG	1
	Engine (slide) Excluding ceramics	PRT	VOL	86	N	SL	ENG	1
	Thermaco Remote Gas Valve (Only)	PRT	THERM	RC	NG	VAL		1
	Slide Control Gas Valve Teddington Valve 3173/011	PRT	VAL	SL	UN	0	TED	1
	Remote handset	PRT	THERM	RO	HS	1		
	Spark generator	PRT	VAL	SG	UN	NG	TC	1
	Spark generator 3 x HT leads	PRT	VAL	SL	UN	NG	SI	1
	Slide control mechanism 860	PRT	VAL	SL	86	MC	SI	1
	Remote / Slide Pilot assembly Thermaco NG OXI-PG-82-460	PRT	VAL	PI	RO	PL	Therm	1
	Vermiculite chippings	PRT	CER	SIR	86	VER		
	Forest Log Set	PRT	CER	SIR	86	FO		1
	Woodland Log Set	PRT	CER	SIR	87	WL		1
	New Forest Log Set	PRT	CER	SIR	88	NF		1
	Beach Driftwood Set	PRT	CER	SIR	89	BD		1

SECTION 21: CONTACT DETAILS

GENERAL HELP LINE

08432 890102

Mon to Fri 10:00 to 15:00

SPARE PARTS

If you need assistance or wish to purchase spare parts

Call us on 08432 890102 Mon to Fri 10:00 to 15:00

Contact us by email spareparts@siroccofire.pl

Purchase spare parts direct from our website www.siroccofires.com

Spare parts are managed by our UK partner company Lodestar-Delta Ltd

Lodestar-Delta Ltd T/A Sirocco

Unit 1, 11 Weir St, Blackburn, Lancashire BB2 2AN

TECHNICAL

If you need technical assistance by a Sirocco trained engineer

Call us on 0843 289 0102 Mon to Fri 10:00 to 15:00

Contact us by email tecassist@siroccofire.pl

View our latest products and use our on-line services; www.siroccofires.com

Nad Lasem 8, Zabia Wola

96-321 Zelechow

Poland

WARRANTY

For warranty registration assistance

Call us on 08432 890102 Mon to Fri 10:00 to 15:00

Contact us by email customercare@siroccofire.pl

Our Warranty Statement

5 YEAR WARRANTY STATEMENT

You have purchased your new Sirocco appliance that has been made to the highest standards. When properly maintained and used the appliance will perform perfectly for many years and is warranted for 12 months from date of purchase for parts and labour as covered by the terms and conditions of warranty, verification may be required of the defect by a Sirocco engineer, or a Sirocco appointed engineer, provided that such parts have been subjected to normal conditions of use. In addition, there is a further 4-year parts only warranty available at no extra cost; this is limited to the repair or replacement of parts found to be defective. To qualify please ensure the appliance is serviced every year as required by law and that a service kit is used which is available direct from Sirocco

Registration of guarantee and

Sirocco Sp. z o.o. has a commitment to "quality as regards customer care and service" and therefore it is important that you and your installer complete your warranty form completely and correctly and return it to us within 28 days of date of purchase. Alternatively, you can complete the form online at www.siroccofires.com and follow the link on the home page headed "guarantee registration". In addition, a gas safety certificate must be issued by the installer and you are required by law to register the appliance within 30 working days with the local authority building control and you will find this information to assist you on the same location as the guaranteed registration. This guarantee applies to gas fires only, electrical appliances are not included.

By registering you will assist us in identifying the correct parts you may require in the future or ensuring that the correct parts are given to an engineer for a service visit. Please ensure you provide this to us within 28 days stated and include the Gas Safe notification number or your warranty will not be valid.

Regular Servicing

It is essential that your Sirocco appliance is serviced, by a suitably qualified Gas Safe engineer or a Sirocco authorised appointed engineer to carry this out at least within each twelve-month period as required by law, and to qualify for your 5-year warranty. It should be noted that that each appliance has different requirements for parts to be replaced at a service and you should consult and purchase the service packs form the sirocco website relevant to each model and service interval as part of the conditions of your 5-year warranty

Contacting Sirocco

If you need to contact Sirocco for a Warranty service or to purchase spare parts the contact details and procedure are printed on the back page of your installation/user guide

What else should I know?

The following is an extract from the full terms and conditions for warranty which are located in your instruction/user guide and on the Sirocco website.

The following are not covered by warranty: paint work in the fire chamber, fire fronts, and decorative trims, crazing of ceramic components, and marks or clouding on glass, batteries, electronic or electric/mechanical components such as remote controls. The warranty is only valid if registered within 28 days of purchase providing all the information stated (proof of purchase will be required and a gas safety certificate must be issued by the engineer on installation and with every service) registration with the local authority via Gas Safe is mandatory and is only for a UK domestic installation, provided the appliance has been installed in accordance to the installation instructions and in compliance with current regulations in a correctly functioning flue. Validation of your installation will be required prior to warranty service/repair; there will be a fee for this. No other validation will be accepted by Sirocco. Accidental damage or improper use is not covered by warranty. This guarantee is non-transferable and is made to the original owner provided that the purchase was made through an approved Sirocco Fires stockist

This guarantee is none transferable and is made to the original owner, provided that the purchase was made through a company appointed stockist

Any installation, labour, transportation or other related costs expenses arising from defective parts repair replacement or otherwise of same will not be covered by this guarantee nor shall the company assume responsibility for same. Furthermore, the company will not be responsible for any incidental, indirect or consequential damages except as provided by law. All other guarantees – expressed or implied – with respect to the product, it's components and accessories or any obligations or liabilities on the part of Sirocco Fires are hereby expressly excluded. Sirocco Fires neither assumes nor authorises any third party to assume on its behalf, any other liabilities with respect to the sale of this Sirocco Fire appliance.

Location of your serial number, this will be on the data badge on the appliance which will look something like this and will be located under the fire or behind the fascia.

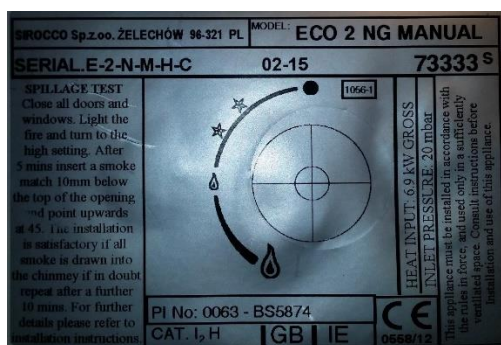

SIROCCO Sp.zo.o. ŻELECHÓW 96-321 PL

MODEL - VOLA 860 HE

SERIAL:
VOL-86HE-N-RT-0 02-15 00140^S

HEAT INPUT: 6,2 KW GROSS PINo: 86CP44
INLET PRESSURE: 20mbar NG. CAT. I_{2H} GB & IE



Efficiency class-1

This appliance must be installed in accordance with the rule and used only in a sufficiently ventilated space. Consult instructions before installation and use of this appliance.

For full terms and conditions of warranty please refer to our website www.siroccofires.com

SIROCCO Sp. Zo. o
C/O UNIT 1
THE WEIRS
11 WEIR STREET
BLACKBURN
LANCASHIRE,
BB2 2AN

PLEASE
AFFIX
STAMP
HERE

----- FOLD HERE -----